

KICO
THE HOME. MADE IN ITALY.

Milano 2018

Salone del Mobile

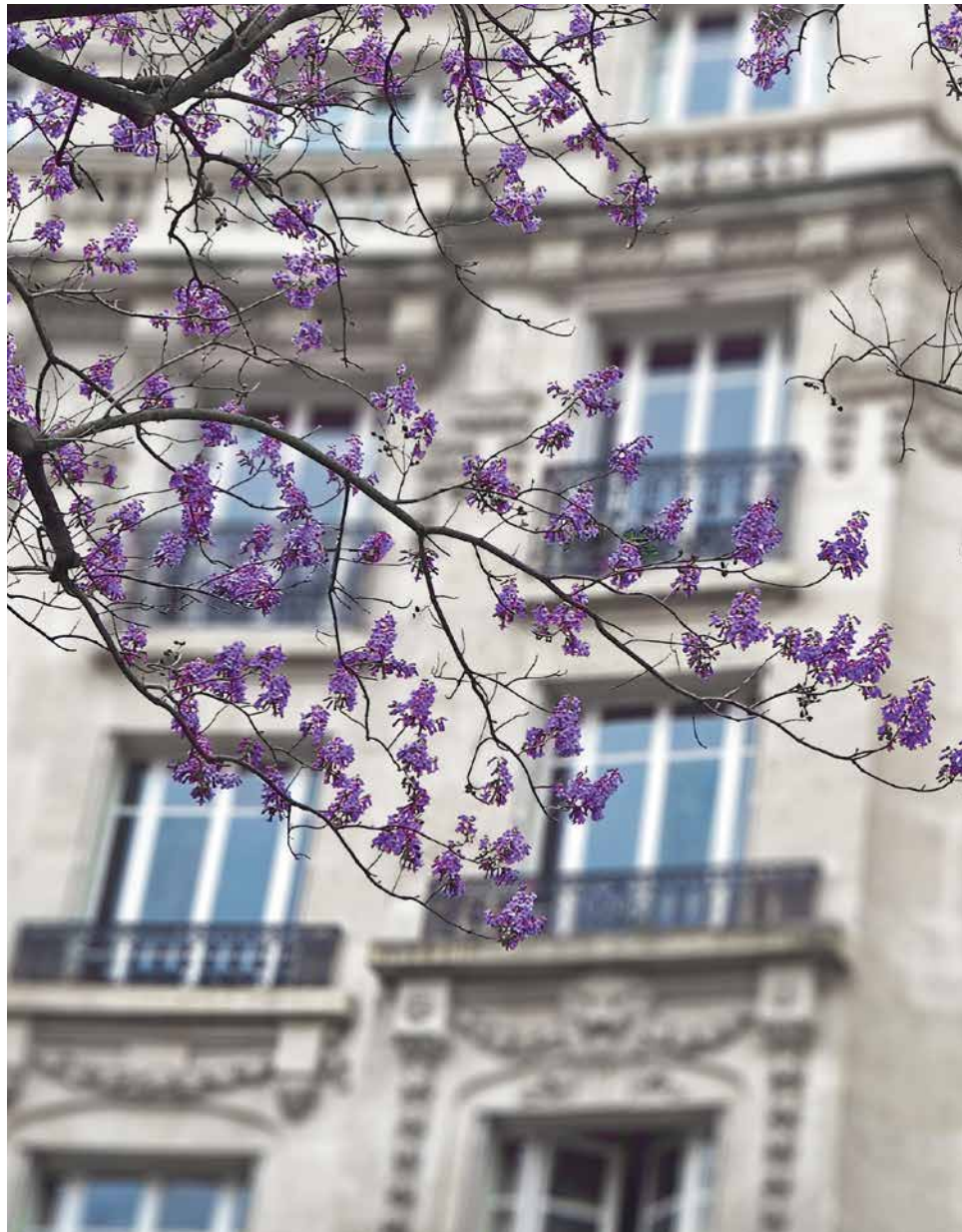

17 / 22 April 2018
Salone del Mobile

NEWS

Day & Night Collection

N° 01

Un risveglio a Parigi

Wake up in Paris

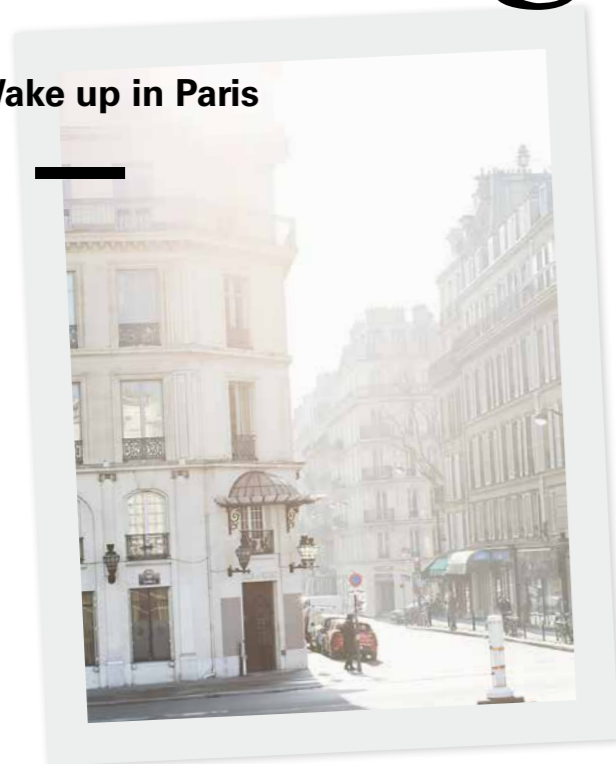

①

Tavolo Moor in versione quadrata: struttura e piano in Rovere Grisaglia / Moor table squared: structure and top in Rovere Grisaglia



②

Tavolo Moor in versione rettangolare: struttura in Rovere Grisaglia e top in pietra sinterizzata Calacatta / Moor table rectangular: structure in Rovere Grisaglia and top in natural stone



③

Tavolo Moor in versione ellittica: struttura in Rovere Camogli e top in laccato Grigio Teca / Moor table elliptic: structure in Rovere Camogli and top in Grigio Teca lacquered



— Tavolo Moor: struttura in rovere termocotto e piano in pietra naturale.

Disponibile in 4 differenti soluzioni: quadrato, tondo, rettangolare, ellittico.

— Moor table: structure in rovere termocotto and top in natural stone. Available

in 4 different solutions: squared, circle, rectangular, elliptic.





— Madia VIKI: struttura ed ante in laccato Grigio Maya, aperture alare, raster in vetro e top in pietra naturale.
 — VIKI sideboard: Grigio Maya matt lacquered structure, wing doors opening, glass raster and natural stone.



**Contenere con eleganza
in equilibrio
tra forma e materia**

**Storing with elegance, in balance
between shape and materials**

— Madia VIKI in versione credenza in impiallacciato, con LED integrato e cassettera sospesa attrezzabile.
 — VIKI sideboard, veneered, LED integrated and internal suspended drawers.

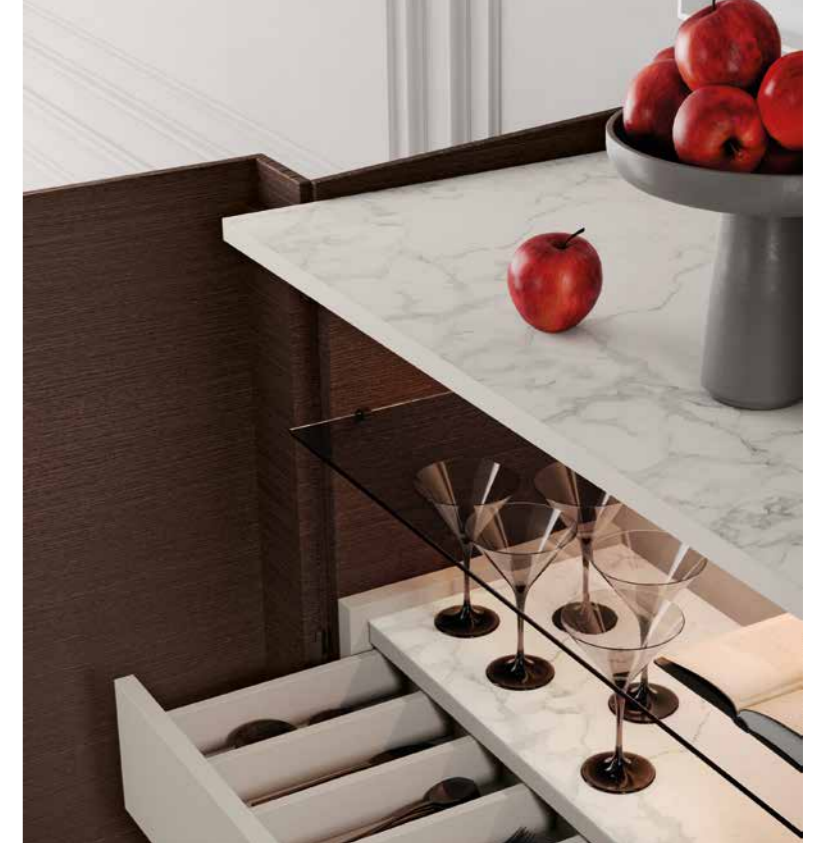

Apriamo le porte sulla zona notte

—
Have a look at the night collection

17 / 22 April 2018
Salone del Mobile

- A sinistra armadio centro stanza con modulo terminale a giorno. Sullo sfondo, settimanali GRIP in Rodin Olmo e laccato opaco Grigio Fumo.
- Terminal open module integrated in the wardrobe, on the left. GRIP towers in Rodin Olmo and Grigio Fumo matt lacquered.

- In questa pagina: comò GRIP in finitura laccato opaco Grigio Fumo e armadio battente Vertigo con profilo gola e terminale a giorno.
- On this page: GRIP chest of drawers finished in Grigio Fumo matt lacquered and Vertigo swinging doors wardrobe with groove and terminal open module.

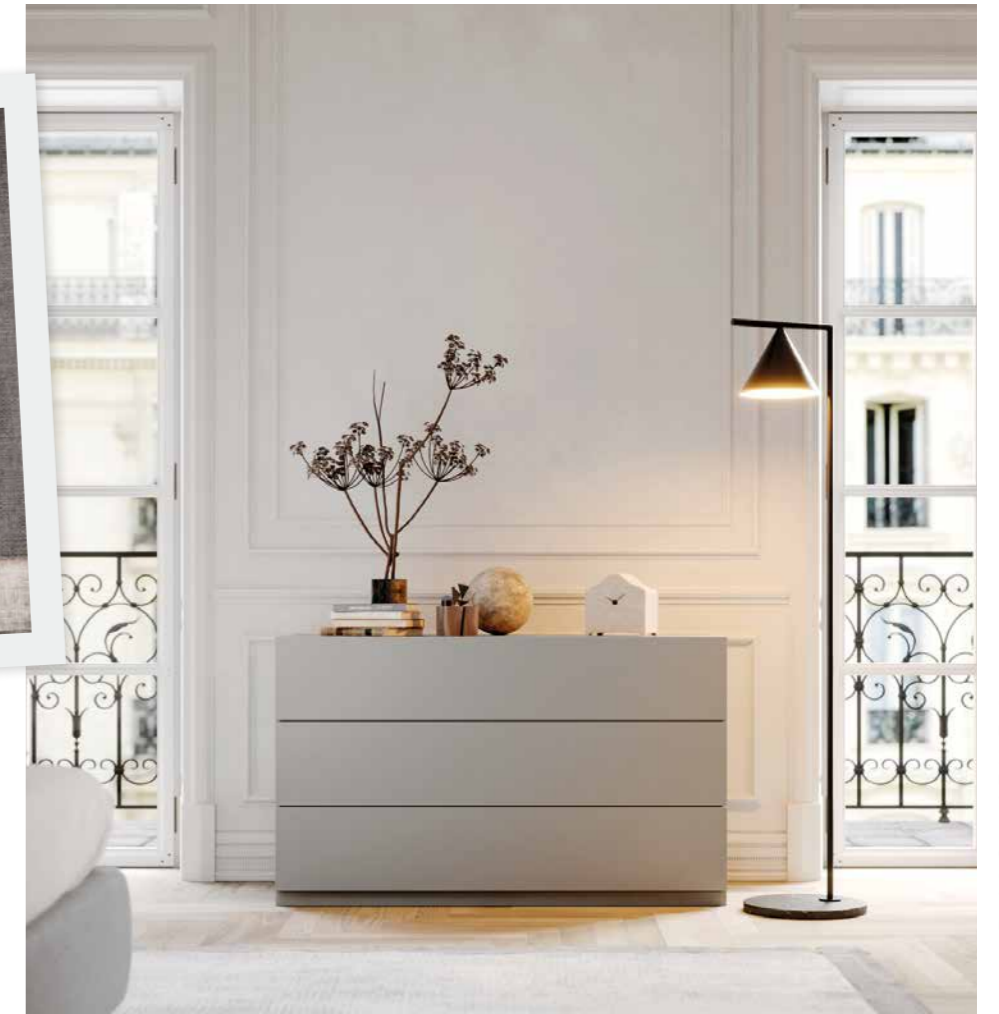

Pad 8 Strand E46 E50



— Gruppo notte GRIP, caratterizzato da un profilo in alluminio laccato che funge da gola per l'apertura dei cassetti.
 — GRIP bedside units: a lacquered aluminium profile, defines the drawers opening.



— Nella pagina di destra: letto con sistema boiserie BUILD-ME, modulabile in larghezza e finiture.
 — On the right page: bed with BUILDME boiserie system, different modularities and finishes available.



Geometrie pure e cemento

Pure geometry and cement



— A destra, tavolo allungabile GOLD in legno Rovere termocotto. Il piano è realizzato con delle doghe di diverse dimensioni. Sedia Ambra con seduta in tessuto e gambe in tinta Olmo Scuro, nella versione senza braccioli.
— On the right page, GOLD extending table finished in Rovere termocotto wood. Top in wooden slats with different widths. Ambra chair in fabric and Olmo Scuro legs, no armrest-chair version.



Il tavolo in legno allungabile dalle forme pure

The pure shape of a veneered
extendible table





**Marmo / legno / vetro
cassetti con divisori interni
per organizzare con ordine**

—
**Marble, wood, glass. Internal drawers
for an easy storage**

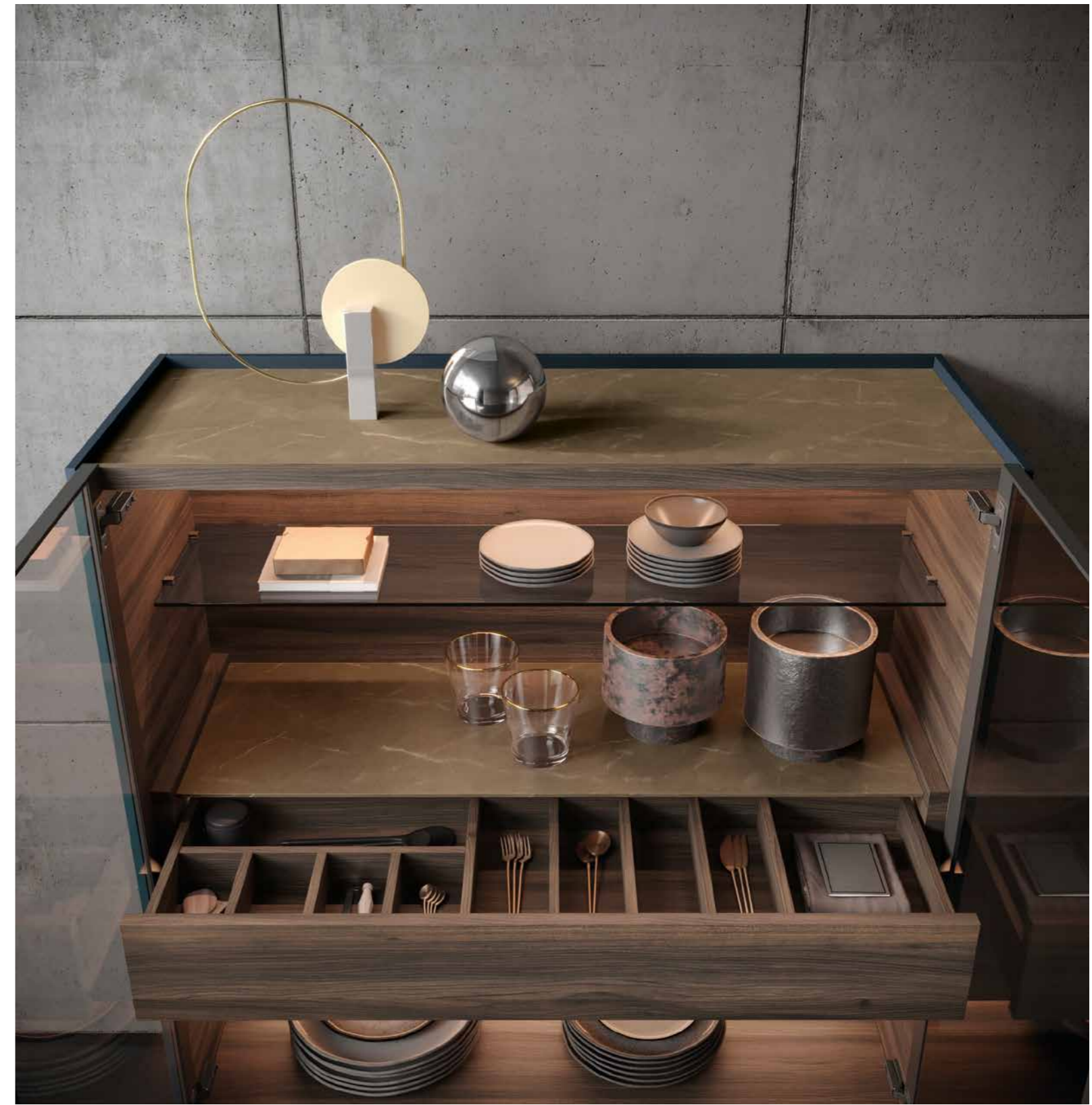

17 / 22 April 2018
Salone del Mobile

Pad 8 Strand E46 E50



— Madia ARYA nelle due versioni disponibili.
Ante in vetro e cassetti interni sospesi con portaposate.

— ARYA sideboard in two available versions.
Glass doors, internal drawers with cutlery trays.

Kico



**In un'unica parete attrezzata,
uno spazio per lavorare, una libreria
e una vetrina per le cose speciali**

—

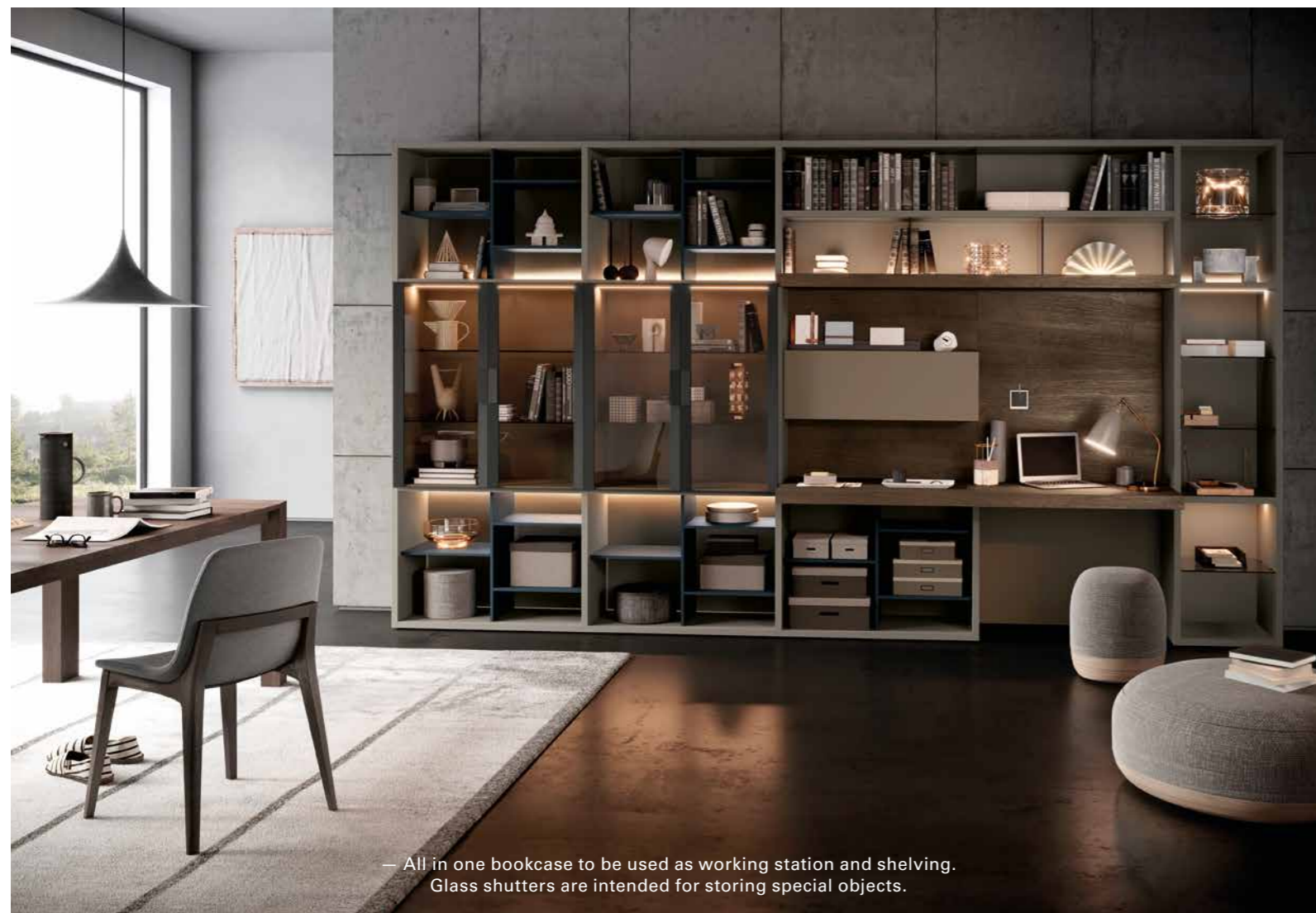

— All in one bookcase to be used as working station and shelving.
Glass shutters are intended for storing special objects.

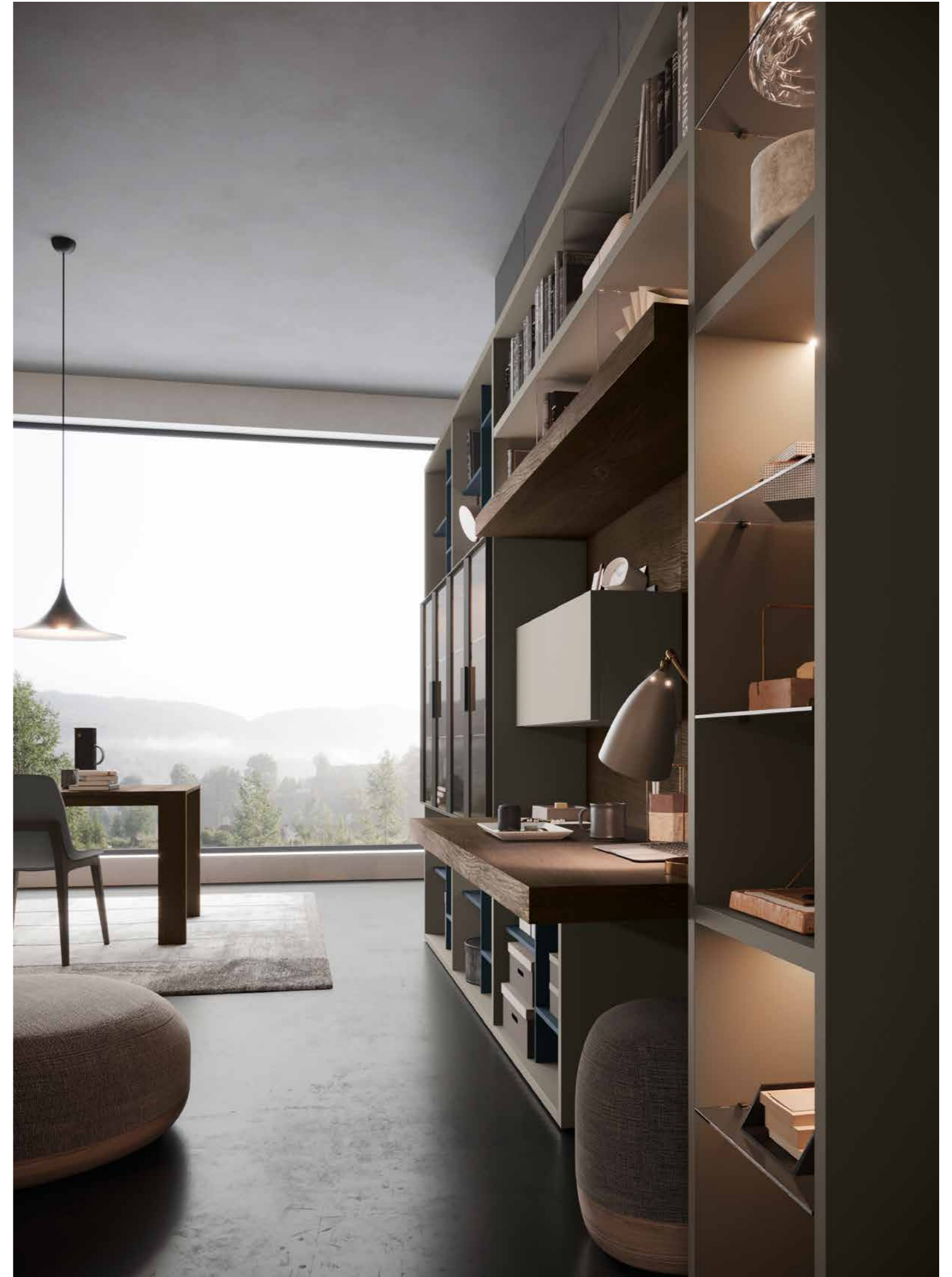

PENSIERI LIBERI / FREE THOUGHTS

L'intervista in 3 domande / The interview in 3 questions

I dettagli non sono solo dettagli, sono loro che fanno il design.



DANILO RADICE

DETAILS ARE NOT JUST DETAILS. THEY CREATE THE DESIGN.

Quale ruolo hanno questi oggetti in relazione allo spazio?

Creare significa prima di tutto saper cogliere la bellezza e l'armonia e trasformarle in un'idea. È così che prende forma la mia linea di prodotti per KICO. Ad esempio il sistema notte / giorno Teca è nato smaterializzando una semplice scatola ma preservando la struttura esterna con l'obiettivo di rendere vero protagonista il contenuto piuttosto che il contenitore.

Ci spieghi brevemente le tue fasi di progettazione che passano dall'idea creativa al prodotto finale. Prima di tutto bisogna sempre capire e comprendere il Dna dell'azienda con la quale si sta collaborando. Stabilire un target di riferimento, cogliere l'essenza e la natura di un brand è quello che ti permette di non sbagliare strada. Si inizia poi a dar libero sfogo alla fantasia e come designer posso dire che questo è sicuramente il momento più gratificante. L'unico limite è rappresentato dalla tua creatività, la matita è libera sul foglio guidata solo da un'idea, nessun vincolo, nessuna restrizione. È proprio da questo momento che viene fuori il bozzetto, un'idea primordiale, spesso disegnata fuori scala ma che contiene in sé tutti gli elementi chiave del progetto. Da qui si passa alla fase definitiva che prevede lo studio dell'industrializzazione e prototipazione.

Quali sono per te le tre keywords che esprimono al meglio il termine "design"?
PROPORZIONE / PASSIONE / DETTAGLIO

Passione: è l'amore che mi porta a fare questo lavoro e non sentire la stanchezza. Che mi porta ad essere orgoglioso di essere per il quarto anno il designer di un'azienda che è per me quasi come una seconda famiglia.

Proporzione: non c'è bellezza senza equilibrio, tra le forme geometriche di una composizione giorno così come nelle linee morbide e sinuose di un imbottito.

Dettaglio: i dettagli non sono solo dettagli, sono loro che fanno il design. La differenza tra il banale e lo straordinario si nasconde proprio in elementi piccoli, talvolta impercettibili ma che appagano l'occhio umano spesso senza spiegare perché.

1

What role do these objects have in relation to space?

To create means first of all to be able to catch the beauty and harmony and turn them into an idea. This is how my KICO product line was born. For example, the Teca night / day system was created by dematerializing a simple box but preserving the external structure with the aim of making the content - rather than the container - a true protagonist.

2

Briefly explain to us your design phases that go from the creative idea to the final product. First of all we must always understand and share the DNA of the company we are collaborating with. Establishing a target audience, catching the essence and nature of a brand helps you avoiding making mistakes. Then you let your imagination free and as a designer I can say that this is definitely the most rewarding moment. The only limit is your creativity, the pencil is free on the sheet guided only by an idea, no constraints, no restrictions. This is the moment the sketch comes out, a primordial idea, often drawn out of scale but which contains in itself all the key elements of the project. From here we move on to the final phase which involves the study of industrialization and prototyping.

3

3 keywords to define your idea of "design"?
PROPORZIONE / PASSION / DETAILS

Passion: It means to me Love that leads me working very hard while not feeling tired - that makes me feel proud of being for the fourth year the designer of a company that now is almost a second family to me.

Proportion: there is no beauty without balance, as through the geometric shapes of living room composition as in the soft and sinuous lines of padded furniture.

Details: which are not just details but the features of the design. The difference between trivial and extraordinary is hidden in small, sometimes imperceptible elements that satisfy the human eye often without explainable reasons.

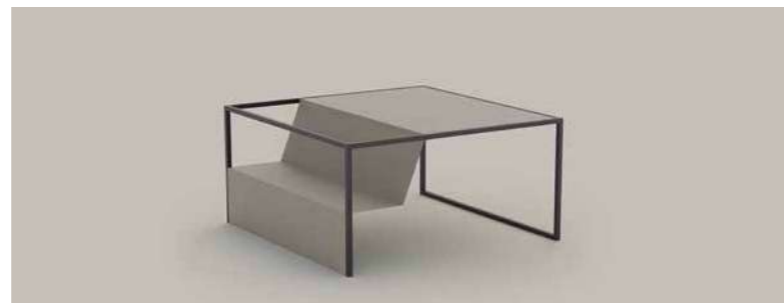

Punto sul prodotto

Focus on product

TECA

significa ripostiglio, deposito,
per raccogliere, collezionare,
custodire, oggetti, pensieri
e passioni.

/

**Teca è un concetto composto.
Modulabile e declinabile
all'infinito in ogni parte della casa.**

/

**Teca è una struttura realizzata
senza giunture,
con luce integrata nella struttura.**

TECA

It means space, storage, to collect and keep not only objects but your own thoughts and passions. / Teca is a composite concept. Modulable and infinitely declinable in every part of the house. /

Teca is a structure created with no joints, Led light integrated in the structure and back panels customizable in every Kico finish.

Kico



**Un utilizzo attento della successione di vuoti e volumi.
Il tono complessivo dell'oggetto è opulento,
ma raccolto nel suo rigore.**



A smart use of empty spaces and volumes. The overall effect makes the object opulent and distinguished at the same time.



— L'elemento TECA nasce per caratterizzare tutti gli elementi della zona notte. L'armadio battente VENERE in finitura laccato Beige Kenya, nell'immagine a destra, è proposto con il modulo TECA SPACE sia come elemento centrale che come elemento terminale. A completamento, gruppo notte TECA e il letto TECA VISION.



— TECA is the element that distinguishes every element of the bedroom. Beige Kenya lacquered Venere wardrobe, on the right, with TECA SPACE module in the middle and as terminal unit. TECA bed set and TECA VISION bed complete the entire furnishing of this room.

Appartamento in città

—
City apartment

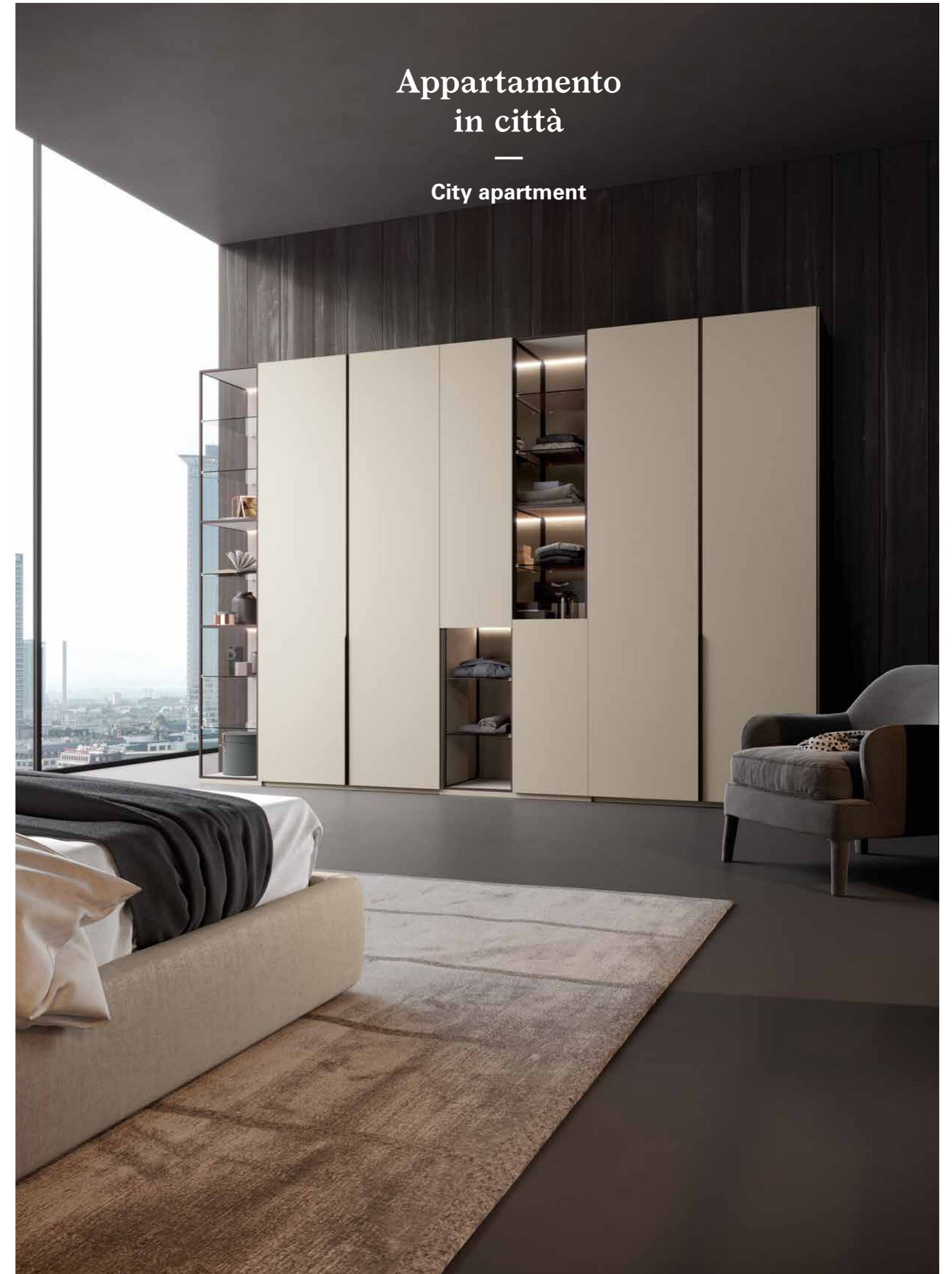



Punto sul prodotto

Focus on product

Un'isola per contenere e mostrare

An island to store and show

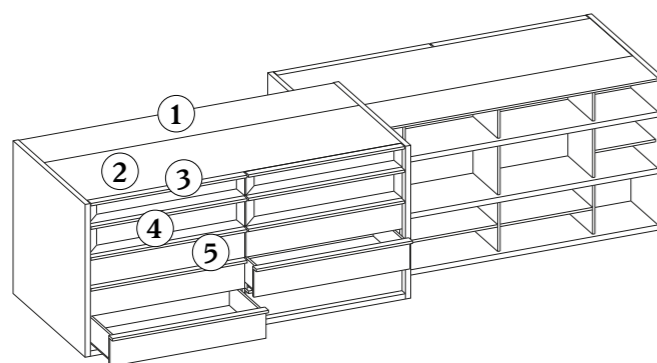

- ① Top superiore trasparente extrachiari temperato. / Tempered extra clear transparent top.
- ② Top superiore realizzabile in finiture legno, con rivestimento in pelle o con pietra sinterizzata. / Top available in wood finishes or leather trim or sintered stone.
- ③ Cassetto modello premium con frontale in vetro porta gioie e porta accessori. / Jewelry drawer with glass front in premium model.
- ④ Cassetto modello premium e frontale in vetro. / Drawerchest premium model with glass front in premium model.
- ⑤ Cassetto modello premium e frontale wood. / Drawer with wooder front in premium model.

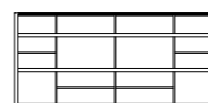

— Hive
Isola

H 874 / L 1732 / P 900



Punto sul prodotto: Gruppo Kyoto
Focus on product: Kyoto group

Vano nascosto
Hidden storage unit

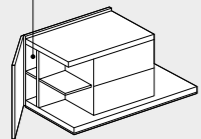

Ripiani in vetro
Glass shelves

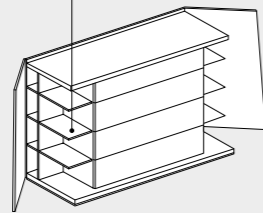

Specchio estraibile
Mirror

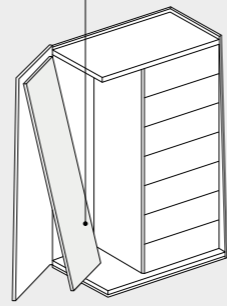

Ripiani / Shelves

Vetro / Glass 1 finitura / 1 finishes

Struttura / Structure

Melaminico base / Melaminico 3 finiture / 15 finiture
Laccato opaco liscio / Laccato opaco rigato / Laccato lucido / Impiallacciato 21 colori Kico / 21 colori Kico / 21 colori Kico / 9 essenze
/ Base melamine / Melamine 3 finishes / 15 finishes
Matt smooth lacquered / Matt striped lacquered / Glossy lacquered / Venered Kico RAL / Kico RAL / Kico RAL / 9 essences

Cassetti / Drawers

Melaminico base / Melaminico 3 finiture / 15 finiture
Laccato opaco liscio / Laccato opaco rigato / Laccato lucido / Impiallacciato 21 colori Kico / 21 colori Kico / 21 colori Kico / 9 essenze
/ Base melamine / Melamine 3 finishes / 15 finishes
Matt smooth lacquered / Matt striped lacquered / Glossy lacquered / Venered Kico RAL / Kico RAL / Kico RAL / 9 essences



— Kyoto Comodino

H 466 / L 931 / P 488

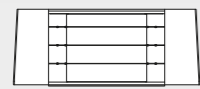

— Kyoto Comò

H 854 / L 1320 / P 538

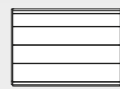

— Kyoto Comò

H 854 / L 1220 / P 538

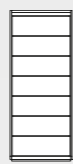

— Kyoto Settimanile

H 1386 / L 620 / P 538



— Kyoto Comodino

H 466 / L 731 / P 488

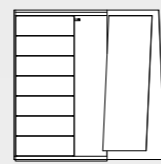

— Kyoto Settimanile

H 1386 / L 920 / P 538

Kyoto

fianchi apribili
per un nuovo modo
di concepire
comò e settimanale

— Openable unit, a new concept of
bedside and high dresser



Punto sull'azienda

Focus on the company

Una lunga storia di passione e mobili

A long journey through passion and furnitures

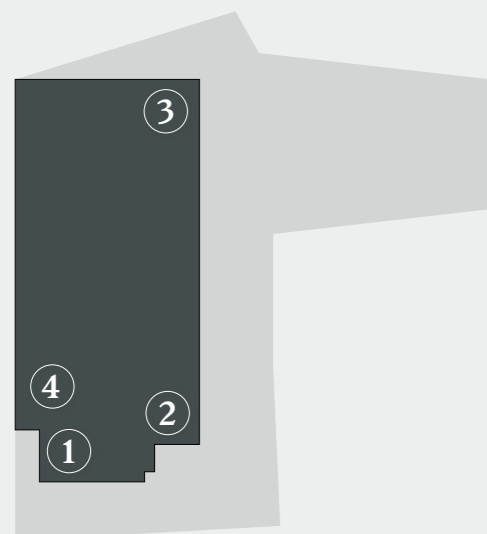

- ① Uffici / Offices
- ② Showroom / Showroom
- ③ Produzione / Production
- ④ Magazzino / Warehouse

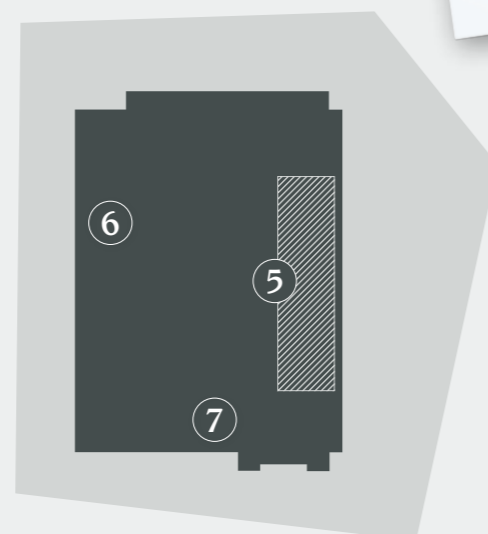

- ⑤ Uffici / Offices
- ⑥ Produzione semilavorato / Production 2
- ⑦ Logistica / Logistics



— Eccellenze italiane che si tramandano di generazione in generazione. Nei primi anni '60 Giuseppe Arangiario comincia l'avventura. Presto si accorge che il Made in Italy è garanzia di successo e inizia l'esportazione delle sue creazioni: in pochi anni diventa uno dei maggiori esportatori di cucine componibili, tanto da indurre una multinazionale americana a credere in lui. La stessa filosofia e dedizione al lavoro vive attraverso la KICO, fondata anni dopo dalla figlia di Giuseppe e da suo marito Quinto. Il Made in Italy e la qualità dei suoi prodotti rappresentano i due pilastri su cui l'azienda crea valore per i propri clienti.

— Italian excellences handed down generation by generation. In the early 60s Giuseppe Arangiario begins the adventure. Soon he realizes that Made in Italy is a guarantee of success and begins the export of his products: in a few years he becomes one of the biggest exporters of kitchens, enough to lead an American multinational company to believe on his holding. The same philosophy and dedication to work keeps on living through KICO founded years later by the daughter of Giuseppe and her husband Quinto. Made in Italy and quality represent the two pillars on which the company creates value for its customers.



Tipologie di finiture materiche e melaminiche / Different typologies of melamine finishes



Essenze in impiallacciato / Several veneered finishes

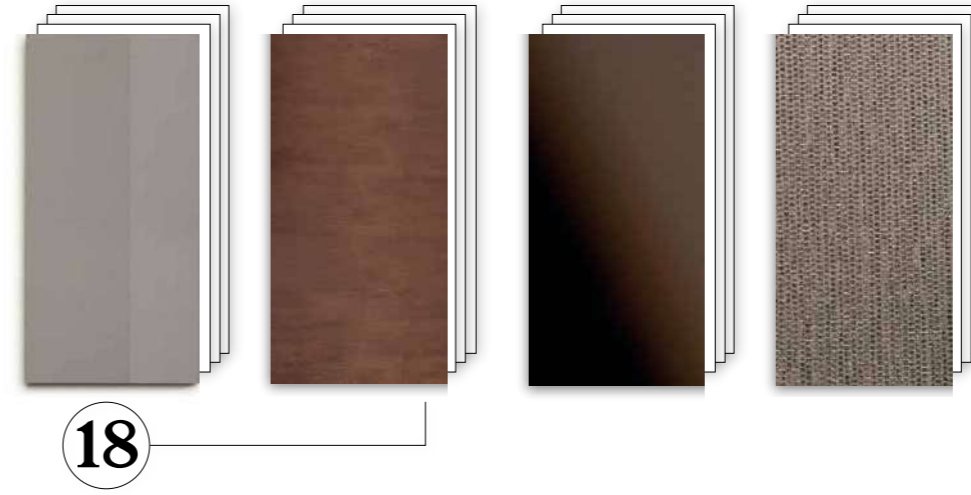

Tipologie di vetri: trasparenti, acidati, semiriflettenti, vetro tessuto / Glasses: trasparent, frosty, stopsol, fabric

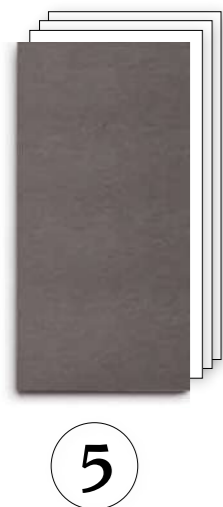

Finiture per elementi metallici / Different colours for metal elements



Pietra e pietra sinterizzata / Stone and sinterized stone

**Parole chiave:
coordinare!
colori / finiture / misure
tutto quello che serve per
sviluppare il tuo progetto
in totale libertà.**

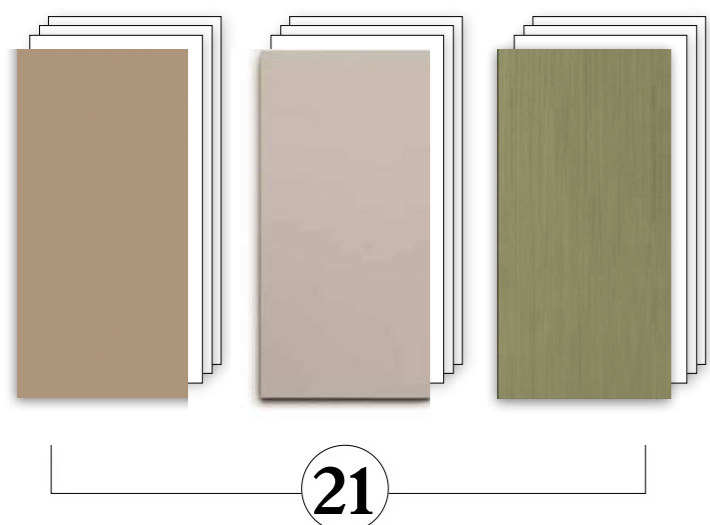

Laccati RAL di serie e 375 a riferimento in 3 effetti differenti / Standard Kico Lacquered colours available - 375 lacquered colours on request - All of them in 3 different effects

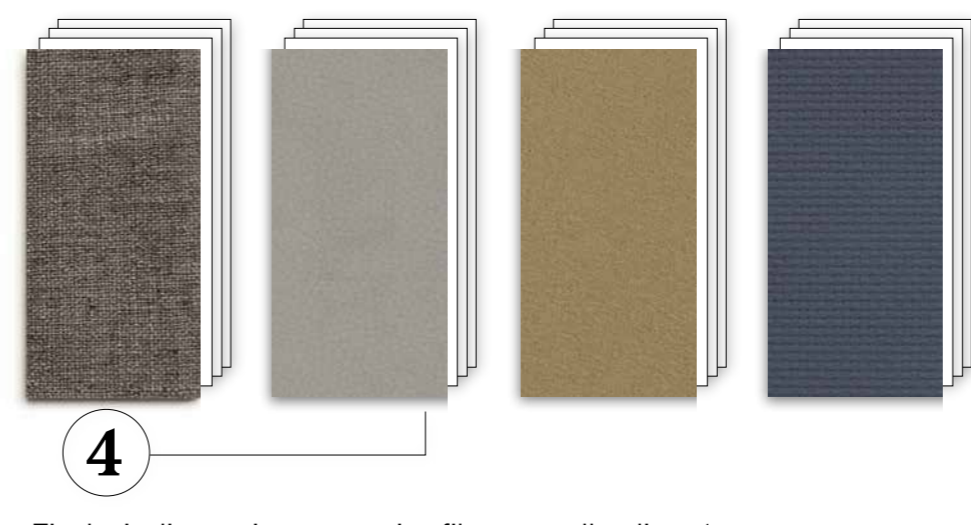

Tipologie di tessuti: tessuto, microfibra, ecopelle e linen / Typologies of coating: fabric, microfiber, eco-friendly leather, linen

**Key word: coordinate!
Colors / finishes / mesures /
accessories all the
freedom you need to
develop your project.**

Con Kico ogni spazio avrà il suo abbinamento perfetto di colori, misure e materiali: ognuno può realizzare la propria casa secondo il suo stile!

Through Kico every room becomes the result of the perfect mix between measures and finishes. Everyone can perfectly fit his own style in his house!

kico.it

—

KICO srl
Via Manfredi 1 - SS 16 km 423 /
64025 Pineto (TE) /
TEL +39 085. 94 63 052 /
EMAIL info@kico.it /
FAX +39 085.79 92 060